

**UNITED STATES DISTRICT COURT  
SOUTHERN DISTRICT OF TEXAS  
HOUSTON DIVISION**

<b>FLOWSERVE CORPORATION and</b>	§	
<b>FLOWSERVE MANAGEMENT</b>	§	
<b>COMPANY,</b>	§	
	§	<b>CIVIL ACTION NO. 4:09-cv-0675</b>
<b>Plaintiffs,</b>	§	
	§	
<b>v.</b>	§	
	§	
<b>HALLMARK PUMP COMPANY, INC.,</b>	§	

**MEMORANDUM AND ORDER**

Pending before the Court is Plaintiffs Flowserve Corporation and Flowserve Management Company’s (“Flowserve”) Motion for Summary Judgment. After considering Flowserve’s arguments, the evidence presented, and the applicable law, the Court finds that the motion should be granted.<sup>1</sup>

**I. BACKGROUND**

Flowserve designs, manufactures and sells industrial pumps, valves, and related products. (Flowserve Am. Compl. ¶ 7, Doc. No. 6.) Defendant Hallmark Pump Company, Inc. (“Hallmark”) distributes competing industrial pumps. (*Id.* ¶ 9.) Hallmark maintains a website in which it advertises and markets the products it offers for sale. (Hallmark Answer ¶ 7, Doc. No. 12.) Flowserve alleges that Hallmark copied and displayed copyrighted images of Flowserve’s Durco brand Mark 3 ANSI chemical process pump (“Durco Mark 3 pump”) on Hallmark’s

---

<sup>1</sup> Hallmark’s counsel withdrew from this case on April 21, 2010. (Doc. No. 37.) The Court issued a stay for thirty (30) days in order to allow Hallmark to retain new counsel. After Hallmark did not secure counsel within thirty days (30), the Court held a status conference on May 28, 2010, during which it vacated the trial date and instructed the parties to file any dispositive motions they desired. On November 4, 2010, Flowserve filed the instant Motion for Summary Judgment. Hallmark remains unrepresented by counsel and has not filed a response to Flowserve’s motion.

website in connection with the sale of Hallmark’s competing ANSI-FLO Model DIII pump (“DIII pump”). (Flowserve Am. Compl. ¶¶ 2-12.) Specifically, Flowserve’s Complaint alleges that Hallmark displayed the following three images in a brochure posted on its website, which are either exact or slightly altered replicas of images for which Flowserve owns a copyright.<sup>2</sup>

**Flowserve IMAGE 1**<sup>3</sup>



**Flowserve IMAGE 2**



**Flowserve IMAGE 3**

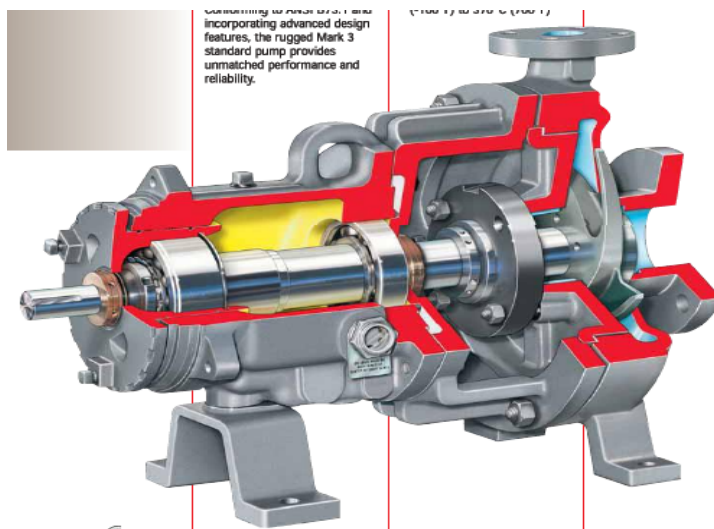

<sup>2</sup> All references to the “Complaint” are to Flowserve’s First Amended Complaint unless otherwise specified. (Doc. No. 6.)

<sup>3</sup> Flowserve did not identify the three disputed images by number in its Motion for Summary Judgment. For ease of reference, however, the Court has labeled and will refer to the above images as indicated.

Flowserve has submitted evidence that Flowserve IMAGES 1 and 3 have been registered and deposited with the Copyright Office. (*See* Certificate of Registration, U.S. Copyright No. TXu1-200-818 (“Certificate of Registration”), Pls.’ Ex. 1; Declaration of B. Joe Schaeff (“Schaeff Decl.”), Pls.’ Ex. 2.) In its Motion for Summary Judgment, Flowserve asserts that the remaining image (Flowserve IMAGE 2) is substantially similar to images included in the Deposit Materials and that the image is also found in Flowserve’s copyrighted Durco Mark 3 brochure (“Flowserve Durco Mark 3 Brochure”). (*See* Schaeff Decl.; Ex. A to Flowserve Am. Compl. at 15 (image), 36 (indicating copyright).) Flowserve’s motion argues that these facts are sufficient to demonstrate Flowserve’s ownership of a valid copyright covering Flowserve IMAGE 2. Following a hearing on Flowserve’s motion, however, Flowserve withdrew its claim of copyright infringement with respect to Flowserve IMAGE 2. (*See* Doc. No. 43.) Thus, hereinafter, the Court will analyze Flowserve’s copyright infringement claims only with respect to Flowserve IMAGES 1 and 3.

On or about September 7, 2008, Hallmark entered into an agreement with dismissed Third-Party Defendant Network Solutions, LLC (“Network Solutions”) to create a new website for Hallmark (“Hallmark website”). (*See* Hallmark’s Third-Party Compl. ¶¶ 12-14, Doc. No. 18.) As part of the process of designing the Hallmark website, Hallmark provided Network Solutions with a brochure for Hallmark’s DIII pump in Microsoft Word (.doc) format (the “ANSIFLODIIIBROCHURE2 Word File”), on or about October 15, 2008. (*See* Log of Hallmark Brochure Upload to Network Solutions Server (“Upload Log”), Pls.’ Ex. 3; *see also* Hallmark’s Third-Party Compl. ¶ 21.) The Upload Log indicates that the ANSIFLODIIIBROCHURE2 Word File was “uploaded successfully” and saved with the file name “ANSIFLODIIIBROCHURE2-2.doc.” (*See* Upload Log.)

On December 1, 2008, Sarah C. Hedrick, a product account manager at Network Solutions, advised Charles French, a website designer at Network Solutions, to “convert the word doc to a pdf.” (See Sarah C. Hedrick Email to Charles French (“Hedrick Email”), Pls.’ Ex. 4.) That French carried out Hedrick’s instruction is evidenced by the Hallmark website, which contains a brochure with the same content and the filename “ANSIFLODIIIIBROCHURE2-2.pdf” (the “Hallmark DIII Brochure,” Ex. B to Flowserve Am. Compl.). The Hallmark DIII Brochure is still available to the public through Hallmark’s website.<sup>4</sup> It contains the three images depicted (and labeled for identification) below, which Flowserve argues are “strikingly similar”—if not identical—to Flowserve’s copyrighted images.

**Hallmark IMAGE 1**



**Hallmark IMAGE 2**



**Hallmark IMAGE 3**

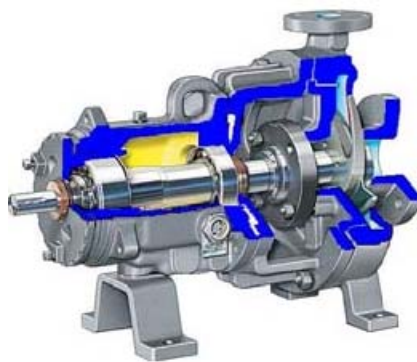

<sup>4</sup> <http://www.hallmarkpumpcompany.com/media/ANSIFLODIIIIBROCHURE2-2.pdf>. (See Fedock Decl., Ex. 12, at ¶ 9.)

After Network Solutions incorporated the Hallmark DIII Brochure containing the three above images into the Hallmark website, Chad Hallmark approved the website design on or around December 3, 2008. (*See* Chad Hallmark Email to Network Solutions (“Chad Hallmark Email”), Pls.’ Ex. 5 (“The complete site looks good except that the address for the Houston office is still incorrect.”).) On December 8, 2008, Jim Hallmark also approved the Hallmark website. (*See* Jim Hallmark Email to Network Solutions (“Jim Hallmark Email”), Pls.’ Ex. 6.)

After being approved by both Chad and Jim Hallmark, the Hallmark website, including the Hallmark DIII Brochure, was made available to the public on or about December 15, 2008. (*See* Network Solutions Customer Log File (“Customer Log”) at 17, Pls.’ Ex. 7.) On February 9, 2009, Flowserve sent a cease-and-desist letter to Hallmark requesting that the infringing images be removed from the Hallmark website. (*See* Flowserve’s Feb. 9, 2009 Cease-and-Desist Letter to Hallmark (“Cease-and-Desist Letter”), Pls.’ Ex. 8.) Hallmark failed to remove the link to the allegedly infringing work within the time specified in the Cease-and-Desist Letter. (*See* Fedock Decl. ¶ 8.) In fact, Hallmark did not remove the link to the allegedly infringing brochure until after Flowserve filed the instant lawsuit, and Hallmark still has not removed the brochure entirely from the Hallmark website.<sup>5</sup>

Flowserve argues that Hallmark’s actions constitute copyright infringement under Title 17 of the United States Code (“the Copyright Act”) and false advertising under Section 43(a) of the Lanham Act. Flowserve contends that Hallmark’s actions were willful in both instances. To remedy Hallmark’s alleged violations, Flowserve’s motion seeks (1) statutory damages provided

---

<sup>5</sup> (*See* <http://www.hallmarkpumpcompany.com/media/ANSIFLODIIIBROCHURE2-2.pdf>; *see also* Fedock Decl., Ex. 12, at ¶¶ 8-9.)

by Section 504 of the Copyright Act in the amount of \$30,000;<sup>6</sup> (2) a permanent injunction pursuant to Section 502 of the Copyright Act and Section 34(a) of the Lanham Act; and, (3) the costs, attorneys' fees, and expenses incurred by Flowserve in protecting its intellectual property rights, as provided by Section 505 of the Copyright Act and Section 35(a) of the Lanham Act, in the amount of \$75,000.

## II. LEGAL STANDARD FOR SUMMARY JUDGMENT

A motion for summary judgment requires the Court to determine whether the moving party is entitled to judgment as a matter of law based on the evidence thus far presented. Fed. R. Civ. P. 56(c). Summary judgment is proper "if the pleadings, depositions, answers to interrogatories, and admissions on file, together with the affidavits, if any, show that there is no genuine issue as to any material fact and that the moving party is entitled to judgment as a matter of law." *Kee v. City of Rowlett*, 247 F.3d 206, 210 (5th Cir. 2001) (quotations omitted). A genuine issue of material fact exists if a reasonable jury could enter a verdict for the non-moving party. *Crawford v. Formosa Plastics Corp.*, 234 F.3d 899, 902 (5th Cir. 2000). The Court views all evidence in the light most favorable to the non-moving party and draws all reasonable inferences in that party's favor. *Id.* Hearsay, conclusory allegations, unsubstantiated assertions, and unsupported speculation are not competent summary judgment evidence. Fed. R. Civ. P. 56(e)(1); *see, e.g., Eason v. Thaler*, 73 F.3d 1322, 1325 (5th Cir. 1996); *McIntosh v. Partridge*, 540 F.3d 315, 322 (5th Cir. 2008); *see also Little v. Liquid Air Corp.*, 37 F.3d 1069, 1975 (5th Cir. 1994) (noting that a non-movant's burden is "not satisfied with 'some metaphysical doubt as to the material facts'") (citing *Matsushita Elec. Indus. Co., Ltd. v. Zenith Radio Corp.*, 475 U.S. 574, 586 (1986)).

---

<sup>6</sup> After withdrawing its copyright infringement claim as to Flowserve IMAGE 2, Flowserve's statutory damages claim is accordingly reduced to \$20,000.

### III. COPYRIGHT INFRINGEMENT

Flowserve urges that Hallmark has infringed Flowserve's copyrights by displaying two of Flowserve's copyrighted images on the Hallmark website without Flowserve's permission. Flowserve contends that, as evidenced by the Certificate of Registration and the Declaration of B. Joseph Schaeff, Flowserve is the owner of a valid copyright covering, *inter alia*, Flowserve IMAGES 1 and 3. Flowserve argues that Hallmark's impermissible copying and displaying of Flowserve IMAGES 1 and 3 constitutes actionable copying and that Hallmark's conduct was willful.

"A copyright infringement claim requires proof of (1) ownership of a valid copyright and (2) actionable copying, which is the copying of constituent elements of the work that are copyrightable." *Bridgmon v. Array Sys. Corp.*, 325 F.3d 572, 576 (5th Cir. 2003) (citing *Eng's Dynamics, Inc. v. Structural Software, Inc.*, 26 F.3d 1335, 1340 (5th Cir. 1994)). A certificate of registration "constitutes prima facie evidence of the validity of the copyright and of the facts stated in the certificate." 17 U.S.C. § 410(c); *see also Norma Ribbon & Trimming, Inc. v. Little*, 51 F.3d 45, 47 (5th Cir. 1995).

"Two separate inquiries must be made to determine whether actionable copying has occurred. The first question is whether the alleged infringer copied, or 'actually used the copyrighted material in his own work.'" *Bridgmon*, 325 F.3d at 576. "As direct evidence of copying is rarely available, factual copying may be inferred from (1) proof that the defendant had access to the copyrighted work prior to creation of the infringing work and (2) probative similarity." *Peel & Co. v. Rug Market*, 238 F.3d 391, 394 (5th Cir. 2001). "Access has been defined to include an opportunity to view the copyrighted work." *Ferguson v. Nat'l Broad. Co., Inc.*, 584 F.2d 111, 113 (5th Cir. 1978). The second element, probative similarity, requires a

showing that the works, “when compared as a whole, are adequately similar to establish appropriation.” *General Universal Sys. v. Lee*, 379 F.3d 131, 142 (5th Cir. 2004) (internal quotation omitted). Alternatively, factual copying may be established without a showing of access “if the two works are so strikingly similar as to preclude the possibility of independent creation.” *Id.*

Once factual copying is established, “[t]he second question is whether ‘substantial similarity’ exists between the copyrighted work and the allegedly infringing work.” *Bridgmon*, 325 F.3d at 576. “To determine whether an instance of copying is legally actionable, a side-by-side comparison must be made between the original and the copy to determine whether a layman would view the two works as ‘substantially similar.’” *Creations Unlimited, Inc. v. McCain*, 112 F.3d 814, 816 (5th Cir. 1997). “[A] determination of substantial similarity should typically be left to the fact-finder.” *Bridgmon*, 325 F.3d at 577. Indeed, “[s]ummary judgment historically has been withheld in copyright cases because courts have been reluctant to make subjective determinations regarding the similarity between two works.” *Peel*, 238 F.3d at 395 n.17 (quoting *Herzog v. Castle Rock Entertainment*, 193 F.3d 1241, 1247 (11th Cir. 1999)). Despite this general rule, the Fifth Circuit, along with other jurisdictions, has held that “summary judgment may be appropriate if the court can conclude, after viewing the evidence and drawing inferences in a manner most favorable to the nonmoving party, that no reasonable juror could find substantial similarity of ideas and expression.” *Peel*, 238 F.3d at 395. Indeed, there is generally a consensus that “non-infringement may be determined as a matter of law on a motion for summary judgment, either because the similarity between two works concerns only non-copyrightable elements of the plaintiff’s work, or because no reasonable jury, properly



instructed, could find that the two works are substantially similar.” *See, e.g., Herzog*, 193 F.3d at 1247.

While there is agreement that *non-infringement* may be determined as a matter of law, there are few instances in which courts in the Fifth Circuit have granted summary judgment in favor of a plaintiff on a copyright infringement claim. Two Texas district courts have held, however, that summary judgment in favor of a plaintiff on a copyright infringement claim may be appropriate in limited circumstances. Certainly, “[w]hile the general rule is that the question of substantial similarity is one for the jury, a court may nonetheless be justified in ruling for a plaintiff on a summary judgment motion when the similarities between plaintiff’s and defendant’s works are so overwhelming as to preclude the possibility of independent creation.” *Wood v. B L Building Co.*, Civil Action No. H-03-713, 2004 WL 5866352, \*9 (S.D. Tex. June 22, 2004) (quoting 3 NIMMER ON COPYRIGHT § 12.10[B][3] (2003) (internal quotations omitted); *see also Biggs v. Cabela’s, Inc.*, No. 4:03-CV-0205-A, 2004 WL 530167, \*4 (N.D. Tex. Feb. 23, 2004) (“While the question of substantial similarity normally is to be left to the fact-finder, summary judgment is appropriate if the court decides that no reasonable juror could make a finding contrary to the one the court concludes is compelled by the summary judgment record.”)

#### **A. Ownership of Valid Copyright**

In this case, the Certificate of Registration and the Declaration of B. Joseph Schaeff demonstrate that Flowserve is the owner of a valid copyright covering Flowserve IMAGES 1 and 3. Hallmark has submitted no evidence that controverts this first element of Flowserve’s copyright infringement claim. Because copyright registration certificates constitute prima facie evidence of ownership and Hallmark has not pointed the Court to any evidence suggesting that

Flowserve does not hold a valid copyright covering the images, the court finds that there is no genuine issue of material fact as to the first copyright infringement element.

### **B. Factual Copying**

Flowserve argues that Hallmark displayed copies or slightly altered copies of Flowserve Images 1 and 3 on its website. As explained above, copying may be established without a showing of access “if the two works are so strikingly similar as to preclude the possibility of independent creation.” *Ferguson*, 584 F.2d at 113. Flowserve argues that this is precisely the circumstance presented in this case. Indeed, Hallmark IMAGE 1 is identical to Flowserve IMAGE 1 and Hallmark IMAGE 3 identical to Flowserve IMAGE 3 except for a change in the color of the highlighting. The similarity of the images is, indeed, so striking that the Court has no doubt that Hallmark copied Flowserve’s images. Moreover, the evidence in the record supports a finding of factual copying under the primary formulation of the test, as there is: “(1) proof that the defendant had access to the copyrighted work prior to creation of the infringing work and (2) probative similarity” between the copyrighted images and the allegedly infringing images. *Peel*, 238 F.3d at 394.

Hallmark certainly had access to Flowserve IMAGES 1 and 3, which have been available to the public via the filing of the copyright registration in 2005, on Flowserve’s publicly accessible website, and in widely distributed advertising materials such as pump product catalogs.<sup>7</sup> Hallmark had the opportunity to view and impermissibly copy Flowserve’s copyrighted images for use in Hallmark’s advertising and on Hallmark’s website through all of these publically available information sources. *See Ferguson*, 584 F.2d at 113 (“Access has been

---

<sup>7</sup> (See, e.g., [http://www.flowserve.com/Products/Pumps/Industries/Pulp-and-Paper/Chemical-and-Liquor/Mark-3-ASME-Standard-Overhung-Chemical-Process-Pump%2Cen\\_US](http://www.flowserve.com/Products/Pumps/Industries/Pulp-and-Paper/Chemical-and-Liquor/Mark-3-ASME-Standard-Overhung-Chemical-Process-Pump%2Cen_US); <http://www.flowserve.com/vgnfiles/Files/Literature/FPD/ps-10-13-e.pdf>.)

defined to include an *opportunity* to view the copyrighted work.”) (emphasis added). Furthermore, there is “probative similarity” between Flowserve’s copyrighted images and the images displayed on Hallmark’s website. As previously discussed, the images are more than adequately similar to establish appropriation.

There is no question that Hallmark engaged in factual copying under either formulation of the test. Hallmark enjoyed ample access to Flowserve’s two copyrighted images and there is most certainly a probative similarity between Flowserve’s images and those displayed on Hallmark’s website. Indeed, the similarity is so striking as to preclude the possibility of independent creation. Thus, with regard to Flowserve IMAGES 1 and 3, Flowserve has established both a valid copyright and factual copying. The Court will now turn to substantial similarity, the final element in the copyright infringement test.

### **C. Substantial Similarity**

Flowserve argues that the two images at issue on Hallmark’s website are substantially similar to Flowserve’s copyrighted images as a matter of law. The Court agrees. As discussed, Hallmark IMAGE 1 is identical to the corresponding Flowserve IMAGE 1, and the other, Hallmark IMAGE 3, is virtually identical to the corresponding Flowserve IMAGE 3, except for a change from red highlighting to blue highlighting. The other highlighting in Flowserve IMAGE 3 (the yellow and light blue) remains unchanged in Hallmark IMAGE 3.

Although summary judgment is generally disfavored on the question of substantial similarity, under the present circumstances, summary judgment in favor of Flowserve is appropriate with regard to both images. Indeed, a valid copyright exists for both images and the similarities between Flowserve’s images and the ones Hallmark displayed on its website are so overwhelming that there is no question Hallmark engaged in actionable copying. Indeed, no

reasonable jury could believe that the images do not rise to the level of substantial similarity. Having completed the second element of the prima facie case for Flowserve IMAGES 1 and 3, Flowserve has established as a matter of law that Hallmark infringed on its copyrights.

**D. Willfulness**

A defendant's infringement is willful "if he knows his actions constitute an infringement; the actions need not have been malicious." *Broad. Music, Inc. v. Xanthas, Inc.*, 855 F.2d 233, 236 (5th Cir. 1988). Infringement can also be willful where a defendant acted with "reckless disregard" for or "willful blindness" to the rights of a copyright owner. *Berg v. Symons*, 393 F. Supp. 2d 525, 540 (S.D. Tex. 2005) (citing *Island Software and Computer Serv., Inc. v. Microsoft Corp.*, 413 F.3d 257, 263 (2d Cir. 2005)). Ignoring a cease-and-desist letter may constitute "willful and deliberate" conduct. *See Chevron Intellectual Prop., LLC v. Allen*, No. 7:08-CV-98-O, 2009 WL 2596610, at \*3-4 (N.D. Tex. Aug. 24, 2009) (holding that defendant's Lanham Act violation was willful and deliberate where it ignored a cease-and-desist letter from plaintiff). Moreover, the defendant's knowledge need not be proven directly, but may be inferred from the defendant's conduct. *See Webloyalty.com, Inc. v. Consumer Innovations, LLC*, 388 F. Supp. 2d 435, 441 (D. Del. 2005).

Flowserve argues that Hallmark's acts of copyright infringement were willful. Indeed, even after the Cease-and-Desist Letter, Flowserve argues, Hallmark continued to use the contested images on its website. Because Hallmark was on actual notice that its website contained copyrighted advertising materials of its competitor and did not remove it, Flowserve argues, Hallmark acted willfully.

Hallmark has submitted no evidence that it was unaware of its infringing conduct. Given the undisputed evidence that Hallmark refused to remove Flowserve's copyrighted images after

being informed that its conduct constituted copyright infringement, the Court agrees that Hallmark's infringement was willful.

#### IV. FALSE ADVERTISING UNDER THE LANHAM ACT

False advertising occurs when a defendant makes a "false or misleading description . . . or representation of fact" "in commercial advertising or promotion [that] misrepresents the nature, characteristics, qualities, or geographic origin of his . . . goods." 15 U.S.C. § 1125(a); *see also Pizza Hut, Inc. v. Papa John's Int'l, Inc.*, 227 F.3d 489, 495 (5th Cir. 2000). A prima facie showing of false advertising requires a plaintiff to establish: "(1) A false or misleading statement of fact about a product; (2) Such statement either deceived, or had the capacity to deceive a substantial segment of potential consumers; (3) The deception is material, in that it is likely to influence the consumer's purchasing decision; (4) The product is in interstate commerce; and (5) The plaintiff has been or is likely to be injured as a result of the statement at issue." *Pizza Hut*, 227 F.3d at 495. Materiality and deception are generally presumed if an advertisement is literally false. *Id.* at 495 ("a plaintiff must demonstrate that the commercial advertisement or promotion is either literally false, or that [if the advertisement is not literally false,] it is likely to mislead and confuse consumers."); *see also Id.* at 497 ("With respect to materiality, when the statements of fact at issue are shown to be literally false, the plaintiff need not introduce evidence on the issue of the impact the statements had on consumers.") "In most situations, the use of a photograph of the plaintiff's product to advertise the defendant's product is a § 43(a) violation." *Compaq Computer Corp. v. Procom Tech., Inc.*, 908 F. Supp. 1409, 1426 (S.D. Tex. 1995); *see also Truck Equip. Serv. Co. v. Fruehauf Corp.*, 536 F.2d 1210, 1215-16 (8th Cir. 1976).

Flowserve argues that Hallmark violated Section 43(a) of the Lanham Act by making a literally false statement or representation about the nature and quality of its product sold in interstate commerce that caused economic and other damage to Flowserve. Specifically, Flowserve offers evidence that Hallmark uses its website to advertise, offer for sale, and sell its industrial pumps to various entities located throughout the United States. (*See, e.g.*, Hallmark's Answer to Compl. ¶17). Hallmark's website contains images of Flowserve's Durco Mark 3 pump as part of its advertising materials for its competing DIII pump. (*See* Ex. B to Am. Compl. at 2; Fedock Decl., Pls.' Ex. 12 ¶¶ 8-9.) Flowserve argues that Hallmark's advertisements falsely represent that the Flowserve images actually depict Hallmark's DIII pumps. (*See* Ex. B to Am. Compl. at 2; Hallmark's Third-Party Compl. ¶ 21.) Thus, Flowserve argues, Hallmark made a literally false statement for purposes of Section 43(a) of the Lanham Act. Because Hallmark uses its website to advertise products on the Internet and to sell products throughout the United States, Flowserve contends, those literally false statements pertained to a product sold in interstate commerce. (*See* Hallmark's Answer to Compl. ¶17.) Flowserve argues that Hallmark's display of Flowserve's pump on the Hallmark website harms Flowserve. Indeed, it argues, Hallmark's actions resulted in false and misleading representations to the consuming public regarding the nature of Hallmark's competing pumps, which impacts Flowserve's business and goodwill.

The Court agrees with Flowserve that Hallmark's actions constitute false advertising in violation of Section 43(a) of the Lanham Act. Hallmark has submitted no evidence to controvert Flowserve's proof that IMAGES 1 and 3 actually depict Flowserve's products, not its own. By posting these images on its website in connection with the promotion of its competing industrial pumps, Hallmark has made literally false representations about the nature of its products. As

explained above, materiality and deception are generally presumed if an advertisement is literally false. It is also clear that Hallmark's products were sold in interstate commerce and that Flowserve is likely to be harmed by its competitor's deception. As such, Hallmark's use of images of Flowserve's products to advertise Hallmark's products constitutes a violation of Section 43(a) of the Lanham Act.

#### A. Willfulness

Similar to willful copyright infringement, a willful Lanham Act violation occurs when the defendant "knows his actions constitute an infringement." *Philip Morris USA Inc. v. Lee*, 547 F. Supp. 2d 685, 693 (W.D. Tex. 2008). Courts have also recognized "that 'willful blindness' is equivalent to actual knowledge under the Lanham Act." *Microsoft Corp. v. Software Wholesale Club Inc.*, 129 F. Supp. 2d 995, 1010 (S.D. Tex. 2000) (citing *Hard Rock Cafe Licensing Corp. v. Concession Servs., Inc.*, 955 F.2d 1143, 1148 (7th Cir. 1992)). Accordingly, as with copyright infringement, courts "have found willful conduct where a defendant acts with 'reckless disregard for, or [with] willful blindness' toward" a Lanham Act violation. *Philip Morris*, 547 F. Supp. 2d at 693 (internal quotations omitted). Ignoring a cease-and-desist letter can constitute "willful and deliberate" infringement. *Chevron Intellectual Prop.*, 2009 WL 2596610, at \*3-4.

Despite Flowserve's request to remove Flowserve's copyrighted images from the Hallmark website, Hallmark did not remove the link to the brochure containing the images until after Flowserve filed this lawsuit. (See Fedock Decl. ¶ 8.) Moreover, the images are still available at the same web address, although the main page of Hallmark's website no longer links to the web address.<sup>8</sup>

---

<sup>8</sup> (See <http://www.hallmarkpumpcompany.com/media/ANSIFLODIIBROCHURE2-2.pdf>; see also Fedock Decl., Ex. 12, at ¶ 9.)

The Court agrees with Flowserve that Hallmark acted with, at a minimum, reckless disregard with respect to its false advertisement of its DIII pump. Indeed, Hallmark ignored Flowserve's Cease-and-Desist letter, which put Hallmark on notice that it was advertising using images that did not depict its products. Moreover, both Chad Hallmark and Jim Hallmark independently reviewed and subsequently approved the website containing the Hallmark DIII Brochure before it was made available to the public. (*See* Chad Hallmark E-mail; Jim Hallmark E-mail.) Certainly, Hallmark's management knew or should have known that the images of Flowserve's pumps were not images of its own pumps, but rather images of its competitors' similar pumps. In sum, when it received Flowserve's Cease-and-Desist Letter, Hallmark most certainly had actual knowledge that the images used in its brochure were literally false. At the very least, Hallmark acted with reckless disregard toward the possibility that the images it used misrepresented the nature of its products. Hallmark's actions, therefore, constitute a willful violation of Section 43(a) of the Lanham Act.

## **V. REMEDIES**

### **A. Statutory Damages**

A "copyright owner may elect, at any time before final judgment is rendered, to recover, instead of actual damages and profits, an award of statutory damages for all infringements involved in the action, with respect to any one work, . . . in a sum of not less than \$750 or more than \$30,000 as the court considers just." 17 U.S.C. § 504(c)(1). "In a case where the copyright owner sustains the burden of proving, and the court finds, that infringement was committed willfully, the court in its discretion may increase the award of statutory damages to a sum of not more than \$150,000." 17 U.S.C. § 504(c)(2); *see also Broad. Music*, 855 F.2d at 236.



Although the Copyright Act does not provide a formula for determining the amount of damages in a particular case, courts have broad discretion in determining a damage award within the range provided by statute. *See Broad. Music*, 855 F.2d at 237. In this case, Flowserve has elected to recover statutory damages. In its Motion for Summary Judgment, Flowserve requested \$30,000 in actual damages; \$10,000 for each of the infringing images. Because Flowserve has withdrawn its copyright infringement claim with regard to one of the three images originally in dispute, the Court accordingly adjusts Flowserve's claim to \$20,000 in statutory damages.

The Court agrees with Flowserve that \$10,000 per work infringed is an appropriate damages award in this case. Indeed, the evidence shows that Hallmark willfully used its competitor's copyrighted images to sell its own products. As Hallmark's actions were willful, this Court could award up to \$150,000 for each of the infringed images. A much lower award of \$10,000 per work, however, reasonably compensates Flowserve and deters Hallmark from engaging in such conduct in the future.

#### **B. Injunctive Relief**

The Copyright Act's remedies for infringement also allow a court to award "grant temporary and final injunctions on such terms as it may deem reasonable to prevent or restrain infringement of a copyright." 17 U.S.C. § 502(a). Similarly, Section 34(a) of the Lanham Act authorizes courts to "grant injunctions . . . to prevent a violation under subsection (a), (c), or (d) of" Section 43 of the Lanham Act. 15 U.S.C. 1116(a). Flowserve requests a permanent injunction to prevent Hallmark from displaying images of Flowserve's products in Hallmark's advertising, including on Hallmark's website.

A party seeking a permanent injunction must establish “(1) that it has suffered an irreparable injury; (2) that remedies available at law, such as monetary damages, are inadequate to compensate for that injury; (3) that, considering the balance of hardships between the plaintiff and defendant, a remedy in equity is warranted; and (4) that the public interest would not be disserved by a permanent injunction.” *eBay Inc. v. MercExchange, L.L.C.*, 547 U.S. 388, 391 (2006); *see also id.* at 392 (“This approach is consistent with our treatment of injunctions under the Copyright Act.”); *Mary Kay, Inc. v. Weber*, 661 F. Supp. 2d 632, 639-41 (N.D. Tex. 2009) (applying the *eBay* factors to a Lanham Act violation).

The Fifth Circuit has found irreparable injury in trademark infringement cases where “[t]here was a substantial threat to [the plaintiff’s] goodwill and the value of its . . . mark.” *Paulsson Geophysical Servs., Inc. v. Sigmay*, 529 F.3d 303, 313 (5th Cir. 2008). Irreparable injury has also been found where the defendant’s actions “caused a likelihood of confusion among consumers.” *Mary Kay*, 661 F. Supp. 2d at 640; *see also Petro Franchise Sys., LLC v. All Am. Properties, Inc.*, 607 F. Supp. 2d 781, 794-95 (W.D. Tex. 2009). Most importantly, “[i]rreparable harm is presumed when a copyright is infringed.” *Entm’t & Sports Programming Network, Inc. v. Edinburg Cmty. Hotel, Inc.*, 735 F. Supp. 1334, 1343 (S.D. Tex. 1986) (“*ESPN*”); *see also Atlantic Recording Corp. v. Falgout*, No. 06–3784, 2007 WL 4163430, at \*3 (E.D. La. Nov. 21, 2007) (citing *Atari Inc. v. N. Am. Philips Consumer Elec. Corp.*, 672 F.2d 607, 620 (7th Cir. 1982)).

Flowserve argues that Hallmark’s actions create a substantial threat to Flowserve’s goodwill and brand name that have been established over the course of more than 50 years. Hallmark’s use of literally false advertisements, Flowserve contends, also harms Flowserve by deceiving Flowserve’s potential consumers regarding the source and quality of the pumps its

competitor, Hallmark, offers for sale. Moreover, absent an injunction, Flowserve argues, it will also be irreparably harmed by Hallmark's continued display of Flowserve's copyrighted images on Hallmark's website.<sup>9</sup> The Court agrees that Flowserve has been and will continue to be irreparably harmed by Hallmark's blatant appropriation of its copyrighted images absent an injunction.

The remedies available at law, including monetary damages, are inadequate to compensate Flowserve for its injuries. Indeed, injunctions are especially appropriate where the damage to plaintiff cannot be quantified, and therefore cannot adequately "be undone by monetary remedies." *Paulsson*, 529 F.3d at 313; *see also PIU Mgmt., LLC v. Inflatable Zone, Inc.*, 2010 WL 681914, at \*7 (S.D. Tex. Feb. 25, 2010) (finding that the remedies available at law were inadequate where "[t]he amount lost due to confusion as opposed to fair competition [was] . . . difficult, if not impossible, to establish with dependable certainty"). Flowserve urges that its consumer goodwill and widely recognized brand name cannot be quantified, and therefore cannot adequately be remedied with money damages. The damage to Flowserve as a result of consumer confusion is similarly "difficult, if not impossible, to establish with dependable certainty." *See PIU Mgmt.*, 2010 WL 681914, at \*7. The Court agrees that damages alone do not adequately compensate Flowserve.

Considering the balance of hardships between Flowserve and Hallmark, Flowserve argues, a remedy in equity is warranted. The Court agrees that the balance of the hardships weigh in Flowserve's favor. Indeed, the "balance weighs strongly in favor of Plaintiffs where all that is requested is that Defendant comply with the Copyright Act," or by the same logic, the Lanham Act. *Lava Records LLC v. Ates*, 2006 WL 1914166, at \*3 (W.D. La. 2006). This factor

---

<sup>9</sup> (*See* <http://www.hallmarkpumpcompany.com/media/ANSIFLODIIBROCHURE2-2.pdf>; *see also* Fedock Decl., Ex. 12, at ¶¶ 8-9.)

favors the granting of an injunction where Plaintiff “will suffer irreparable harm if an injunction is not entered, as it will lose the ability to control the company image. On the other hand, a permanent injunction will only require the defendants to bring their business into line with the requirements of the law.” *Mary Kay*, 661 F. Supp. 2d at 640. The Court agrees that, without an injunction, Flowserve would be denied the ability to adequately protect its intellectual property, goodwill and brand name. Conversely, granting an injunction would merely require Hallmark to refrain from violating the law by using Flowserve’s intellectual property in its advertisements or on its website.

Finally, Flowserve argues, an injunction will not disserve the public interest, as the public will not be harmed by Hallmark’s inability to copy and display Flowserve’s intellectual property in the connection with the sale of its competing product. Quite to the contrary, “a permanent injunction is appropriate because of the strong public interest in copyright protection.” *Lava Records*, 2006 WL 1914166, at \*3; *see also Warner Bros. Records, Inc. v. Briones*, 77 U.S.P.Q.2d 1253, 1256 (W.D. Tex. 2005) (“the ‘public interest is the interest in upholding copyright protections’”); *Vault Corp. v. Quaid Software Ltd.*, 655 F. Supp. 750, 757 (E.D. La. 1987) (“[T]he public interest can only be served by upholding copyright protections and, correspondingly, preventing the misappropriation of the skills, creative energies, and resources which are invested in the protected work.”). Similarly, “[t]he public interest is always served by requiring compliance with Congressional statutes such as the Lanham Act.” *Quantum Fitness Corp. v. Quantum LifeStyle Centers, L.L.C.*, 83 F. Supp. 2d 810, 832 (S.D. Tex. 1999). “The Supreme Court has held that the Lanham Act exists . . . ‘to protect the ability of consumers to distinguish among competing producers.’” *Mary Kay*, 661 F. Supp. 2d at 640 (quoting *Park ’N Fly, Inc. v. Dollar Park and Fly, Inc.*, 469 U.S. 189, 198 (1985)). The Court finds that an

injunction in this case will, therefore, serve the public interest by requiring Hallmark's compliance with the Copyright Act and the Lanham Act, by protecting Flowserve's copyrights, public image and goodwill, and by protecting consumers' ability to distinguish among competing producers.

In summary, the Court agrees that, Hallmark's actions, if not enjoined, will result in irreparable harm to Flowserve that cannot adequately be compensated by any remedies available at law. Enjoining Hallmark from continued infringement of Flowserve's intellectual property will serve the public interest and will not cause Hallmark undue hardship. The Court, therefore, grants a permanent injunction that prohibits Hallmark from committing any further violations of Flowserve's rights under the Copyright Act and the Lanham Act.

### **C. Attorneys' Fees**

The Copyright Act provides for the imposition of costs and attorneys' fees in favor of the prevailing party. 17 U.S.C. § 505. "[A]ttorney's fees are to be awarded to prevailing parties only as a matter of the court's discretion. 'There is no precise rule or formula for making these determinations,' but instead equitable discretion should be exercised." *Fogerty v. Fantasy, Inc.*, 510 U.S. 517, 535 (1994). The Supreme Court noted in *Fogerty* that courts "have suggested several nonexclusive factors to guide courts' discretion." *Id.* at 535 n.19. For instance, the Third Circuit has indicated that "'frivolousness, motivation, objective unreasonableness (both in the factual and in the legal components of the case) and the need in particular circumstances to advance considerations of compensation and deterrence,'" should be considered in making awards of attorney's fees to a prevailing party. *Lieb v. Topstone Indus., Inc.*, 788 F.2d 151, 156 (3d Cir. 1986). The Supreme Court approved of courts' use of such factors so long as they "are faithful to the purposes of the Copyright Act and are applied to prevailing plaintiffs and

defendants in an evenhanded manner.” *Fogerty*, 510 U.S. at 535 n.19. In the Fifth Circuit, “[a]lthough attorney’s fees are awarded in the trial court’s discretion [in copyright cases], they are the rule rather than the exception and should be awarded routinely.” *Hogan Sys., Inc. v. Cybresource Int’l., Inc.*, 158 F.3d 319, 325 (5th Cir. 1998) (citing *McGaughey v. Twentieth Century Fox Film Corp.*, 12 F.3d 62, 65 (5th Cir. 1994)) (alteration in original).

The Lanham Act also provides for attorneys’ fees in “exceptional cases.” 15 U.S.C. § 1117(a). “An exceptional case involves acts that can be called malicious, fraudulent, deliberate, or willful.” *Schlotsky’s, Ltd. v. Sterling Purchasing & Nat’l Distrib. Co., Inc.*, 520 F.3d 393, 402 (5th Cir. 2008) (internal quotations omitted).

Given Hallmark’s willful and blatant copying of the copyrighted images of its competitor, and its literally false use of the images, coupled with its refusal to remove the infringing images even after receiving Flowserve’s Cease-and-Desist Letter, the Court believes that an award of attorneys’ fees is appropriate in this case. To calculate reasonable attorneys’ fees, the Fifth Circuit uses the “lodestar” method, which is “calculated by multiplying the number of hours reasonably expended by an appropriate hourly rate in the community for such work.” *Heidtman v. County of El Paso*, 171 F.3d 1038, 1043 (5th Cir. 1999). “The court may adjust this lodestar up or down based on what is reasonable under the circumstances of the specific case.” *Randolph v. Dimension Films*, 634 F. Supp. 2d 779, 793 (S.D. Tex. 2009) (internal quotations omitted). “In this final adjustment, the most important factor is the ‘degree of success obtained’ by the prevailing party.” *Id.* “Four other grounds for adjusting the lodestar may apply in copyright cases: the relative complexity of the litigation; the relative financial strength of the parties; the damages awarded; and whether the losing party acted in bad faith.” *Id.*

Flowserve has requested that the Court award \$75,000 in attorneys' fees and costs, which Flowserve asserts represents an amount less than the actual attorneys' fees incurred in prosecuting this lawsuit. In the affidavit attached to Flowserve's motion, it estimates that the value of the unbilled work related to the Motion for Summary Judgment alone is at least \$15,000. Hallmark has not objected to the reasonableness of Flowserve's fees.

The Court believes that the hourly rate and the number of hours expended in preparing this case were reasonable. Flowserve engaged in discovery, responded to a motion to dismiss or to transfer venue, and prepared a motion for summary judgment. As the prevailing party on all but one of its copyright infringement claims, which it chose to withdraw, the Court finds that it is entitled to \$75,000 in attorneys' fees and costs, which the Court believes represents reasonable compensation for protecting its intellectual property rights and preventing Hallmark from continuing to deceive customers about the nature and origin of its products.

## **VI. CONCLUSION**

Flowserve's Motion for Summary Judgment is **GRANTED** as to Flowserve IMAGES 1 and 3. Flowserve is entitled to \$20,000 in statutory damages and Hallmark is enjoined from displaying images of Flowserve's products in Hallmark's advertising, including on Hallmark's website. Flowserve is also awarded \$75,000 in attorneys' fees as the prevailing party in this case.

**IT IS SO ORDERED.**

**SIGNED** at Houston, Texas, on this the 20th day of April, 2011.

A handwritten signature in black ink, appearing to read "Keith P. Ellison". The signature is written in a cursive style with a large initial "K" and "E".

---

KEITH P. ELLISON  
UNITED STATES DISTRICT JUDGE